

Ref.**MI EL3 304****MI E3B 304****ES****INTRUCCIONES DE USO
MINUTERO DE ESCALERA 3 HILOS
IDEAL GARAJES****EN****INSTRUCTIONS MANUAL
Ref. MI EL3 304 / MI E3B 304 3/4 WIRES
STAIRCASE TIMER FOR GARAGES**

INSTRUCCIONES DE USO

Ref. MI EL3 304 / MI E3B 304
MINUTERO DE ESCALERA 3 HILOS IDEAL GARAJES



ESPECIFICACIONES TÉCNICAS

Alimentación	230V~ 50/60Hz
Consumo propio	0,7W
Potencia nominal	16A / 250V~
Lámparas LED	400W
Incandescencia	3.000W
Halógenas 230V	3.000W
Halógenas 12V con transformador	3.000W
Halógenas con trafo ferromagnetico	2.400W
Fluorescencia	1.300W (130µF)
Admite contactor	SÍ
Paso por cero	SÍ
Instalación	3 Hilos
Temporización	2min ~ 40min
Pulsadores luminosos	SI (Máximo 100mA)
Grado de Protección	IP20 según UNE20324
Normativa	UNE-EN60669-2-1 y UNE-EN60669-2-3

INSTALACIÓN

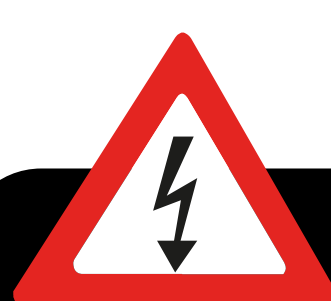

ATENCIÓN: ¡Tensión peligrosa!

¡Los trabajos con equipos eléctricos en la red de 230V, deben de ser realizados exclusivamente por técnicos cualificados!

¡Desconecte la tensión de red antes de proceder al montaje, desmontaje o manipulación del equipo eléctrico!

- Instalación 3 HILOS.

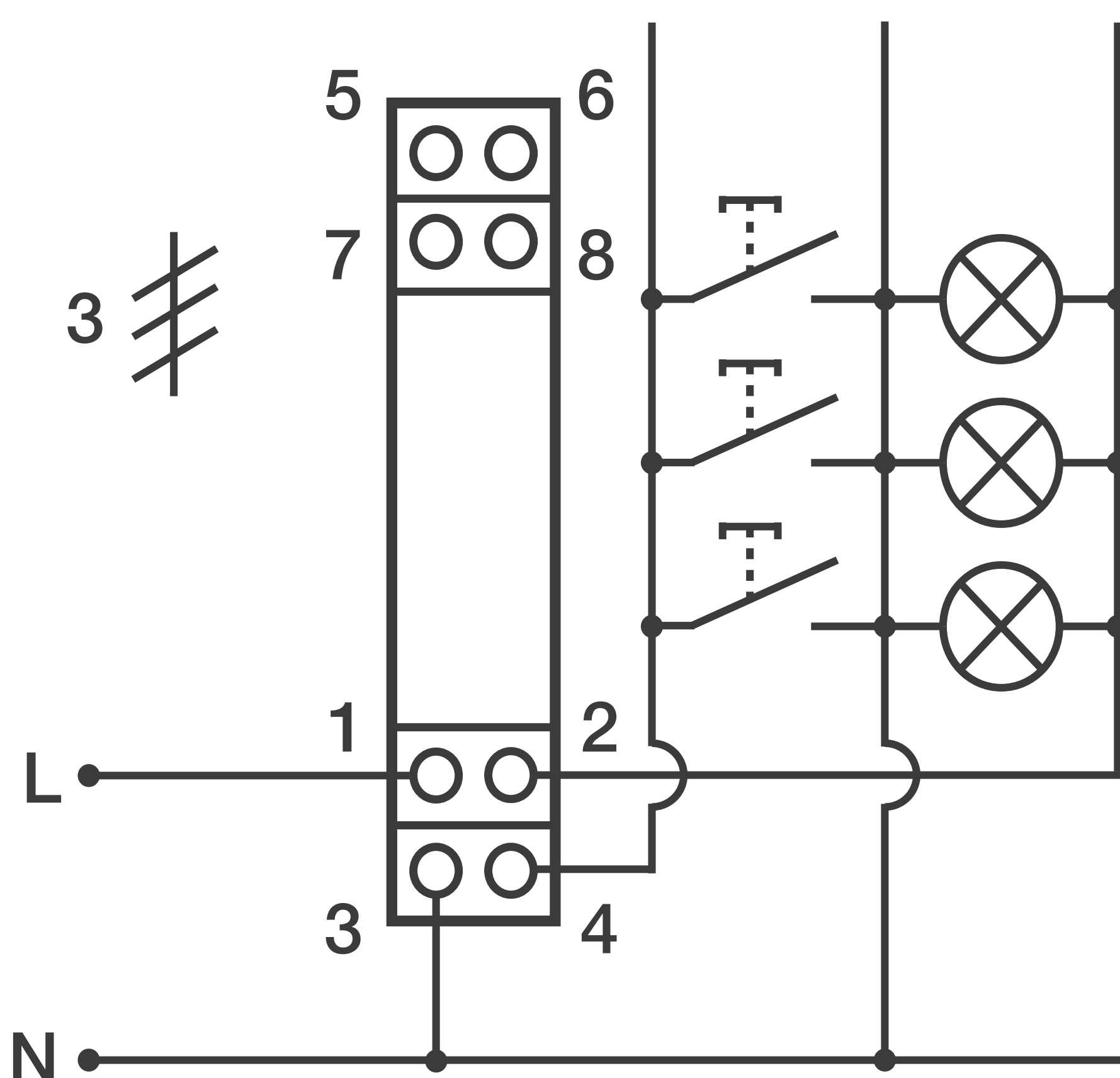

INSTRUCTIONS MANUAL

Ref. MI EL3 304 / MI E3B 304
3/4 WIRES STAIRCASE TIMER FOR GARAGES



TECHNICAL FEATURES

Supply voltage	230V~ 50/60Hz
Consumption	0,7W
Switching capacity	16A / 250V~
LED lamps	400W
Incandescent	3.000W
Halogen 230V	3.000W
12V Halogen with electronic transformer	3.000W
Halogen lamps with ferromagnetic trafo	2.400W
Fluorescent lamps	1.300W (130µF)
Admits contactor	Yes
Zero crossing point	Yes
Installation	3 Wires
Time setting	2min ~ 40min
Luminous pushbuttons	Yes (Max. 100mA)
Type of protection	IP20, UNE20324
According to the Standard	UNE-EN60669-2-1 and UNE-EN60669-2-3

INSTALLATION



WARNING: Hazardous voltage!.

Work with electrical equipment on the 230V mains must be carried out only by qualified technicians!. Switch off the mains before installing, removing or handling of electrical equipment!.

- 3 Wire installation

